



Argonne
NATIONAL
LABORATORY

... for a brighter future



U.S. Department
of Energy

UChicago ►
Argonne_{LLC}



Office of
Science

U.S. DEPARTMENT OF ENERGY

A U.S. Department of Energy laboratory
managed by UChicago Argonne, LLC

Concept for tests of a gallium-cooled target at LENS



The Second Meeting of
The Union for Compact Accelerator-Driven Neutron Sources

UCANS-II

Indiana University
July 2011

J. M. Carpenter, P. E. Sokol, and C. B. Reed

Abstract

Two operable gallium circuits, built for other purposes, exist at Argonne National Laboratory. Previously, we favorably evaluated the prospects for a gallium-cooled beryllium target that could operate on Compact Accelerator-based Neutron Sources (CANS) such as LENS, at higher power densities than the present-day 13-MeV, 15 kW proton beam.

At LENS, already in existence, are an instrumented, electrically heated target mockup and a shielded target area intended for materials testing in a proton beam from the LENS accelerator system.

Here, we outline a concept for testing a gallium-cooled target at LENS, which would involve moving a gallium loop from Argonne to LENS. First tests would be carried out using a mock target, perhaps of stainless steel, cooled by flowing gallium, in the electrically heated apparatus.

Subsequent tests might be done using the second proton beam in the materials testing location. (None of this has yet been approved.)

Successful demonstration of a gallium-cooled target will lead to higher power CANS than present-day water-cooled designs, which are now near heat transfer limits.

OUTLINE

Motivation for gallium cooling

Boiling water heat transfer

Properties of gallium

Assessment of gallium hazards

Working equations for heat transport and fluid flow

Concept for a gallium-cooled CANS target

A scoping calculation: temperatures and pressure drops

Summary

Conclusions and a recommendation

TARGET COOLING

Cooling the beryllium target in compact accelerator-based neutron sources is a considerable challenge at the contemplated proton-beam power densities, although not without precedent. Already at the LENS facility at Indiana University, experience with water cooling seems to be at or to exceed the practical limits of water cooling technology, where conditions approach critical heat flux (CHF) *nucleate boiling limitations* (about 300 W/cm², although this can be exceeded using extreme measures).

Liquid metal coolants offer prospects of higher heat fluxes than water, but the most common ones suffer drawbacks.

BOILING WATER HEAT TRANSFER

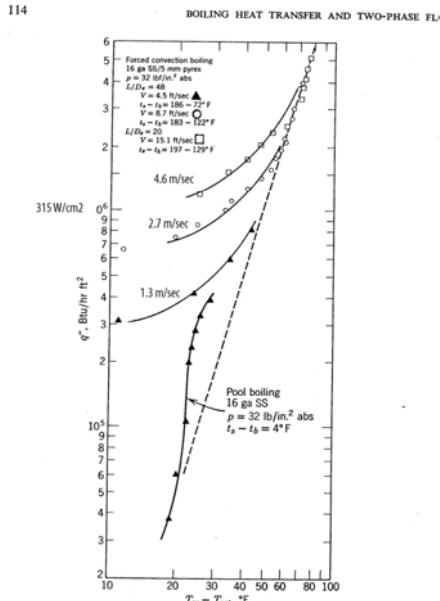

Figure 5-3 Forced convection surface boiling data and pool boiling data for stainless steel tube. From (B30).

The single-phase and nucleate boiling regime at low flow velocities and modest pressures. Region a-b is the practical range shown on the following figure.

The heat flux q'' vs. wall-to-fluid temperature difference for practical flow conditions. In extreme circumstances, q'' can be as large as 1.0 kW/cm², but in practice is 300-500 W/cm².

BOILING WATER HEAT TRANSFER

The region a-b-c is the practical regime illustrated in the previous figure. The heat flux at c is the critical heat flux, beyond which the heat flow is unstable.

The *critical heat flux* q''_{\max} , reached at c, is the maximum feasible in practice.

Vapor blankets the heated surface, and wall temperatures jump to very large values at c', governed by film boiling and radiation heat transfer, called burnout.

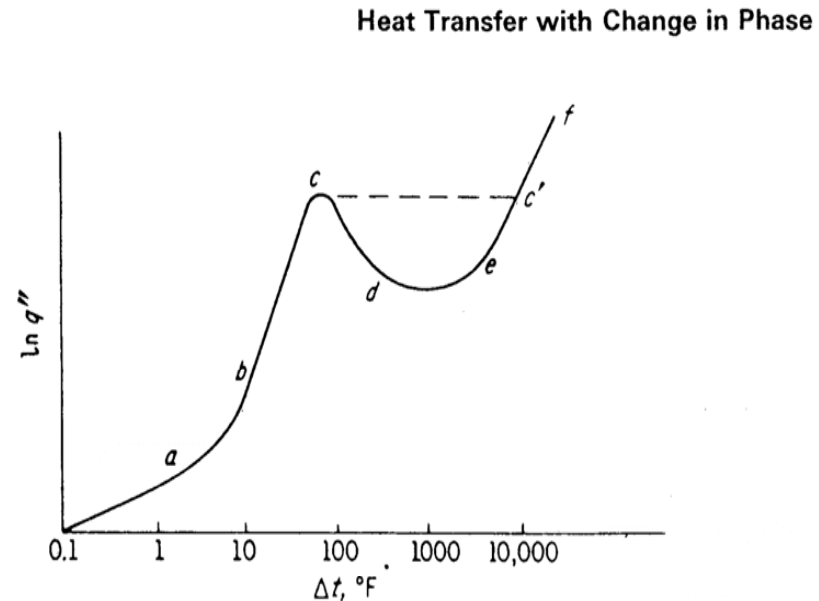

FIG. 11-8. Boiling regimes: Below a, liquid natural convection; a-b, mixed; b-c, nucleate boiling; c-d, mixed; d-e, film boiling; e-f, film boiling and radiation.

LIQUID GALLIUM COOLING

Here, I explore the prospects for a liquid gallium–cooled target (gallium-tin may be eligible), which seems to have few drawbacks and desirable advantages.

Gallium remains in single phase even at elevated temperatures. Gallium is practically non-toxic, readily affordable (~\$500/kg), and its thermophysical properties are well known. There is adequate engineering experience to support design even though its use is not common. A closely related Ga-cooled prototype has operated (ABNCT at MIT). Two gallium loops exist at ANL.

Gallium is compatible with air and water, and with structural and target materials (SS, Ti, Be, rubber-like elastomers) but corrodes aluminum.

PROPERTIES OF GALLIUM

Atomic number $Z = 31$

Mass number $A = 69.7$

Stable isotopes Ga^{69} (60.1%), Ga^{71} (39.9%)

Melting temperature $T_m = 29.8^\circ \text{C}$

Boiling temperature $T_b = 2403^\circ \text{C}$

Vapor pressure: less than 10^{-19} Pa at temperatures below 500°C)

Heat of fusion $Q_f = 5.59 \text{ kJ/mol}$

Density @ 30°C , $\rho = 6.095 \text{ gm/cm}^3$

Thermal conductivity $k = 0.406 \text{ W/cm-}^\circ \text{C}$

Specific heat $C_p = 0.37 \text{ J/gm-}^\circ \text{C}$

Viscosity $\eta = 0.019 \text{ poise} = 0.019 \text{ gm/cm-sec}$

Neutron capture cross section 2.9 barns/atom for thermal neutrons.

resonance integral 21 barns/atom

Activation products Ga^{70} ($T_{1/2} = 21 \text{ min}$), Ga^{72} ($T_{1/2} = 14 \text{ hr}$)

ASSESSMENT OF GALLIUM HAZARDS

The Materials Safety Data Sheet for gallium and gallium-containing alloys indicates caution in handling (use gloves), and avoidance of inhalation of powder and contact with eyes (may cause irritation). Liquid gallium metal is corrosive against many metals. A general appraisal of hazards is that gallium is, in most ways, benign.

Gallium metal is not flammable in air or in contact with water.

Gallium is liquid ($T_m = 30^\circ \text{C}$) at human body temperature but solid at room temperature (in most climates).

HEAT TRANSPORT AND FLUID FLOW

Heat transport from a heated surface to flowing liquid involves numerous quantities:

The (dimensionless) Prandtl number (a property of the fluid only) is

$$\text{Pr} = C_p \eta / k = (0.37)(0.019) / 0.406 = 0.0173.$$

The (dimensionless) Nusselt number, $\text{Nu} = hD_e/k$, so that

$$h = (k/D_e)\text{Nu}, \text{ where}$$

$D_e = 4(\text{flow cross sectional area})/(\text{wetted perimeter of the flow channel})$ is the effective diameter of the channel.

The heat flux q'' is

$$q'' = h \Delta T.$$

HEAT TRANSPORT AND FLUID FLOW

Seban's correlation gives the Nusselt number for liquid metal coolants

$Nu = 5.8 + 0.02 Pe^{0.8}$, where Pe is the Peclet number,

$Pe = RePr$, in which Re is the (dimensionless) Reynolds number

$Re = v D_e \rho / \eta$, in which v is the channel-averaged fluid velocity.

[The Dittus-Boelter equation for non-metallic coolants like water is

$Nu = 0.023 Re^{0.8} Pr^n$, where $n = 0.4$ for heat flow into the fluid.]

The Darcy equation gives the pressure drop Δp in a channel of length L with single-phase fluid,

$\Delta p = f(L/D_e) \rho v^2 / 2$, where f is the Darcy-Weisbach friction factor,

$f \sim 0.184 / Re^{0.2}$ (for $Re > 2 \times 10^4$)

CONCEPTUAL VIEW OF THE GALLIUM-COOLED TARGET SYSTEM

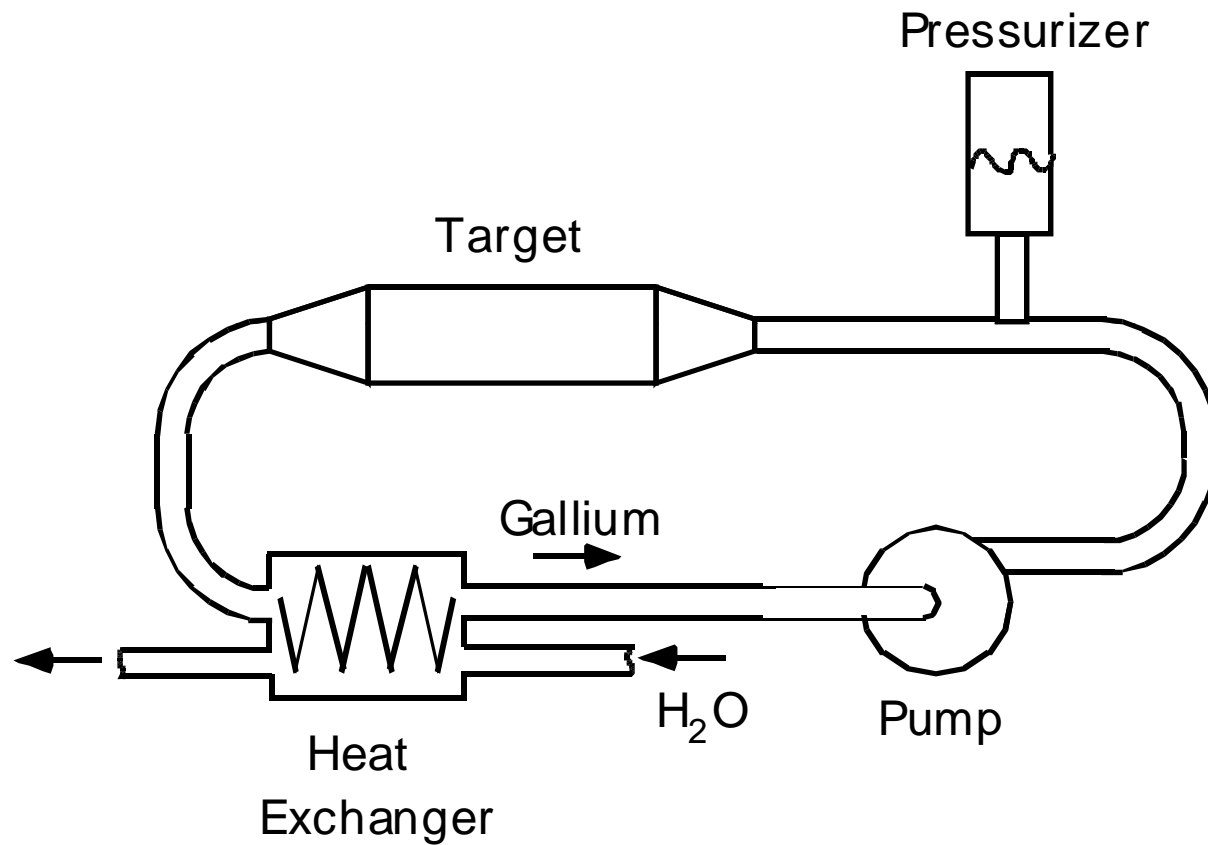

A SCOPING CALCULATION

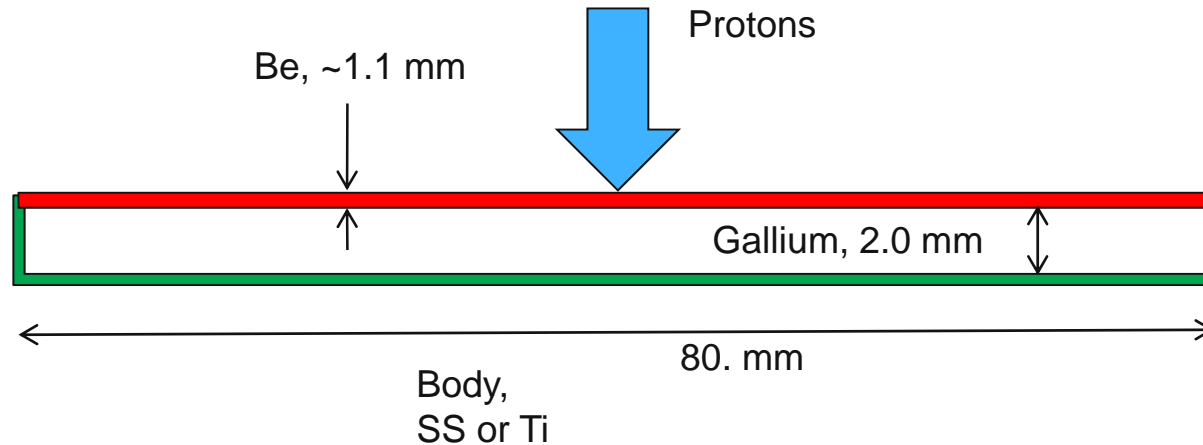

Cross sectional view of Target

I assume a rectangular flow channel of cross section 8 cm wide and 2 mm thick, so that the equivalent diameter is

$$D_e = 4(8)(.2)/[2(8.2)] = 0.390 \text{ cm.}$$

Let the flow velocity be $v = 100 \text{ cm/sec}$. Then the Reynolds number in the cooled cross section is

$$Re = (100)(.390)(6.095)/(0.019) = 12511.$$

A SCOPING CALCULATION

The temperature of the heated surface is the critical quantity for our targets. Beryllium target material and can withstand rather high temperatures.

Assuming 20 kW over an 8-cm diameter, the average heat flux is $q'' = 20000/[(\pi/4)(8^2)] = 398. \text{ W/cm}^2$, but the peak heat flux is about twice that because the proton beam is non-uniform, so I calculate for

$$q_{\text{peak}}'' = 800 \text{ W/cm}^2.$$

This is already considerably beyond common practice for nucleate boiling heat transfer in a water-cooled system, but is in the range considered for CANS.

Proton beamline designers need to provide realistic beam power distributions and peak-to-average power density values to proceed with detailed design.

A SCOPING CALCULATION (CONTINUED)

The Peclet number is $Pe = (0.0173)(12511) = 216.4$, and the Nusselt number is $Nu = 5.8 + .02(216.4^{0.8}) = 7.28$, so that the heat transfer coefficient is

$$h = (0.406)(7.28)/(0.390) = 7.58 \text{ W/cm}^2\text{-}^\circ \text{ C.}$$

Then the wall-fluid temperature difference is

$$\Delta T = 800/7.58 = 105.6 \text{ }^\circ \text{ C,}$$

which is an acceptable figure.

A SCOPING CALCULATION (CONTINUED)

The frictional pressure drop through the target region, assumed to be 10 cm along the flow path, is

$$\begin{aligned}\Delta p &= (0.028)(10./0.390)(6.095)(100^2)/2 = \\ &= 2.188 \times 10^4 \text{ gm-cm/sec}^2/\text{cm}^2 = \\ &= 2.188 \times 10^3 \text{ kg-m/ sec}^2/\text{m}^2 = \\ &= 2.188 \times 10^3 \text{ N/m}^2 = 0.022 \text{ atm},\end{aligned}$$

which is quite small.

The volume flow rate is $V'_{\text{tot}} = vA = (100)(8)(.2) = 160 \text{ cm}^3/\text{sec}$.

The temperature rise in the target channel $\delta T = P/\rho C_p V_{\text{tot}}$ is

$$\delta T = (20000)/[(6.095)(0.37)(160)] = 55 \text{ }^\circ \text{ C}, \text{ which is acceptable.}$$

A SCOPING CALCULATION (CONTINUED)

Assume that the external cooling circuit consists of $D = 2.0$ -cm-diameter tubing (for circular tubes, $D_e = D$), $L = 5$ m long. Then the flow velocity in the tube is $v_{\text{tube}} = V'_{\text{total}} / (\pi 2.0^2 / 4) = 50.9$ cm/sec.

The frictional pressure drop for the external loop depends on the Reynolds number for the flow in the tube,
 $Re = (50.9)(2.0)(6.095) / 0.019 = 3.266 \times 10^4$, for which the friction factor is $f = 0.023$. Thus the pressure drop is

$$\begin{aligned} \Delta P_{\text{external}} &= \\ (0.023)(500/2.0)(6.095)(50.9^2)/2 &= \\ &= 4.54 \times 10^4 \text{ gm-cm/sec}^2/\text{cm}^2 = 4.54 \times 10^3 \text{ N/m}^2 \\ &= 0.041 \text{ atm.} \end{aligned}$$

This is without accounting for the pressure drop in the heat exchanger except to the extent that it is included in the pressure drop in the assumed 5-meter-long external piping.

A SCOPING CALCULATION (CONTINUED)

The acceleration pressure changes at the entrance and exit from the target region more or less cancel around the loop, but the pressure in the target region is smaller than the pressure in the entry tube according to

$$\Delta p_{\text{accel}} = \rho v_{\text{target}} v_{\text{tube}} = 3.102 \times 10^4 \text{ gm-cm/sec}^2/\text{cm}^2 = 3.102 \times 10^3 \text{ N/m}^2 = 0.0282 \text{ atm.}$$

The power required to circulate the fluid is

$$P_{\text{pump}} = V'_{\text{total}} \Delta p_{\text{friction}} = (160 \text{ cm}^3/\text{sec}) \times [(4.54 + 2.19) \times 10^3 \text{ N/m}^2] = 1.08 \text{ N-m/sec} = 1.08 \text{ W,}$$

which does not account for the inefficiency of the pump. A centrifugal pump or an electromagnetic pump might suffice for circulating the coolant.

The volume of gallium in the system is approximately that of the 5-m piping, $V_{\text{gallium}} = 1570. \text{ cm}^3$. The corresponding mass of gallium is $M_{\text{gallium}} = 9.6 \text{ kg}$.

TWO LIQUID GALLIUM SYSTEMS AT ANL

Approximately identical, these were developed in the mid-1990s to cool silicon monochromator crystals for use at Argonne's Advanced Photon Source.

See report by D. Mills and R. Smither, ANL publication LOGOS, ~ 1996.

SYSTEM 1

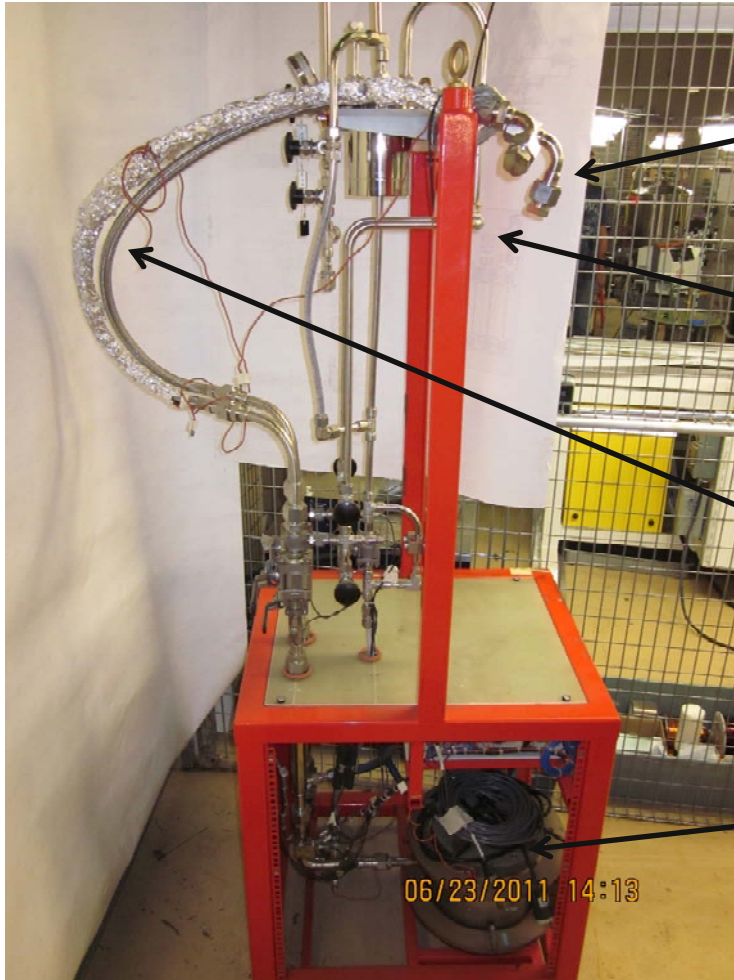

CONNECTION
TO COOLED
DEVICE (TARGET)

EXPANSION VOLUME
& FILLING SYSTEM

FLEXIBLE HOSES

PUMP &
HEAT EXCHANGER

SCHEMATIC DIAGRAM OF ANL GALLIUM CIRCUITS

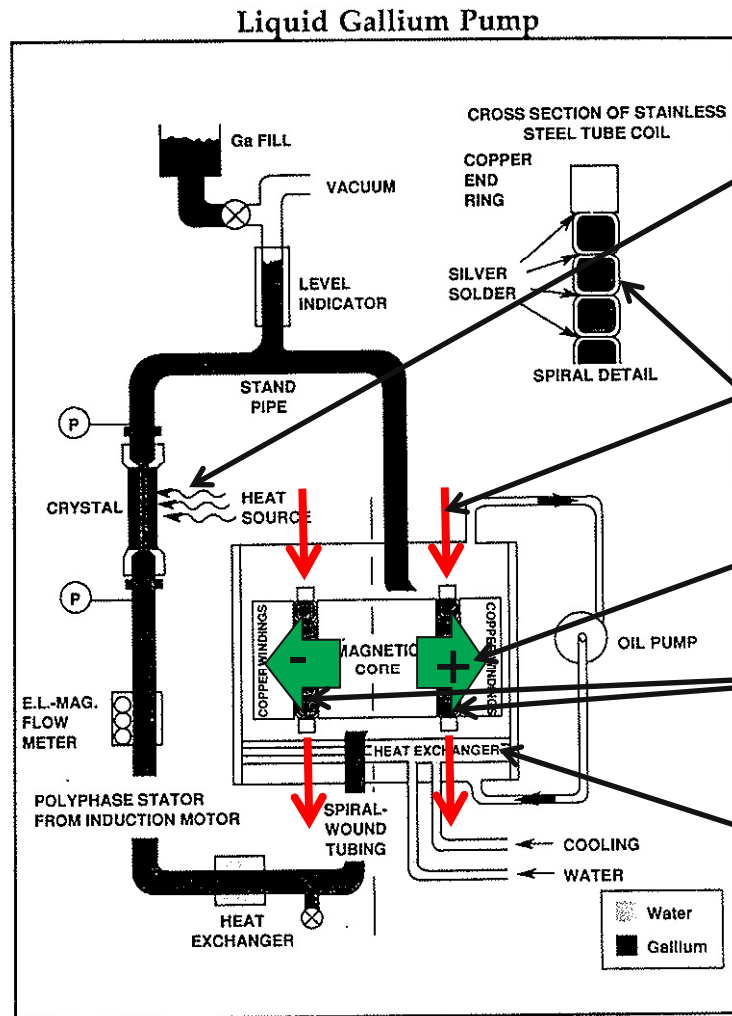

DELIVERS ~ 20 LITER/MIN
WITH PRESSURE RISE ~ 7 ATM.

DC CURRENT J

ROTATING MAGNETIC
FIELD B

FLOW CHANNELS
9 TURNS

HEAT EXCHANGER

NO MOVING PARTS

ELECTROMAGNETIC GALLIUM PUMP FOR SYSTEM 1



DELIVERS HIGH
PRESSURE,
LOW FLOW

(CANS NEED
LOW PRESSURE,
HIGH FLOW)

SYSTEM 2



APPROXIMATELY
IDENTICAL TO
SYSTEM 1

SUMMARY

The scoping results are based on simple analytical calculations and bulk averages, therefore need detailed analysis using modern thermal-hydraulic codes and more precise data.

Summary:

Water-cooled target systems are suitable for CANS up to a certain power level, but present difficulties at envisioned high levels of power. Critical heat flux limitations in nucleate boiling water coolant limit its use in envisioned CANS applications.

Gallium-cooled systems overcome these limitations, and are compatible with water as coolant. Liquid gallium is a convenient, benign coolant, exceeding heat flux requirements, and compatible with all the components of a CANS.

Liquid gallium is compatible with beryllium metal target material.

System components that contact gallium cannot be of aluminum, but SS, titanium, and Tygon are suitable.

CONCLUSIONS

The scoping study reveals that a gallium-cooled system maintains target temperatures ($\sim 100^\circ\text{C}$ above ambient), with modest coolant velocities ($\sim 1\text{m/sec}$, 0.16 l/sec), modest coolant temperature rise ($\sim 55^\circ\text{C}$), affordable coolant mass ($\sim 10\text{ kg}$: $\sim \$5000$.), moderate pumping power (~ 0 . atm pressure drop), moderate target coolant pressure ($\sim 0.3\text{ atm}$ below system driving pressure). The ABNCT source, beryllium target and gallium cooled, built and operated at MIT, is a proof-of-principal prototype and source of experience. A gallium loop exists at Argonne, which could be moved to LENS in an available, well-suited location.

Recommendations:

Move a gallium loop from ANL to LENS for tests.

Elsewhere, design high-power ($>\sim 10\text{ kW}$ beam power) CANS for use of gallium coolant, but begin operation with water coolant. Existing systems will need backfitting of some components. New systems will require engineering for the less familiar gallium coolant, but this seems to present no big problems.

ARRANGEMENTS AT LENS

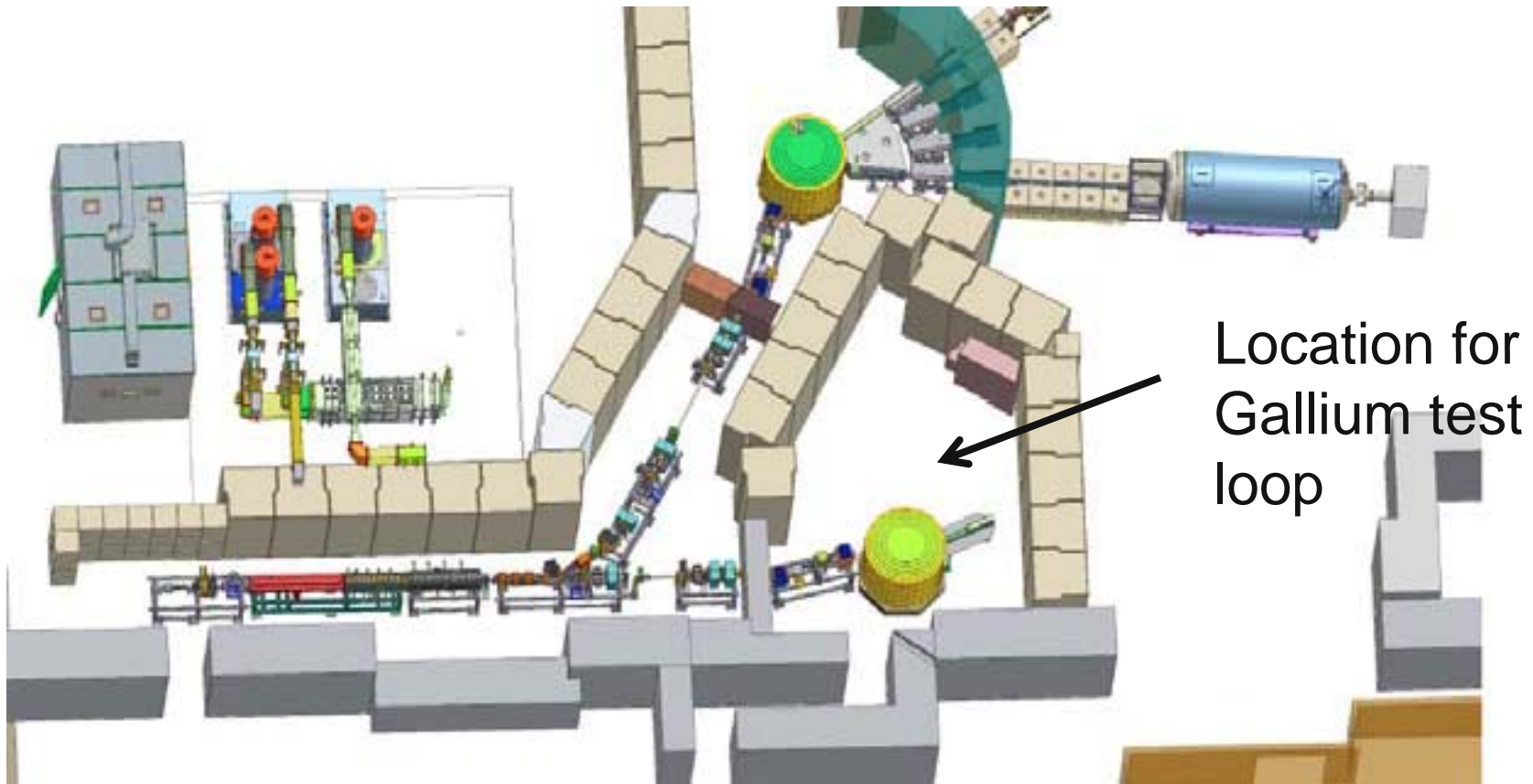

ARRANGEMENTS AT LENS

12 kW Electrical heater tests

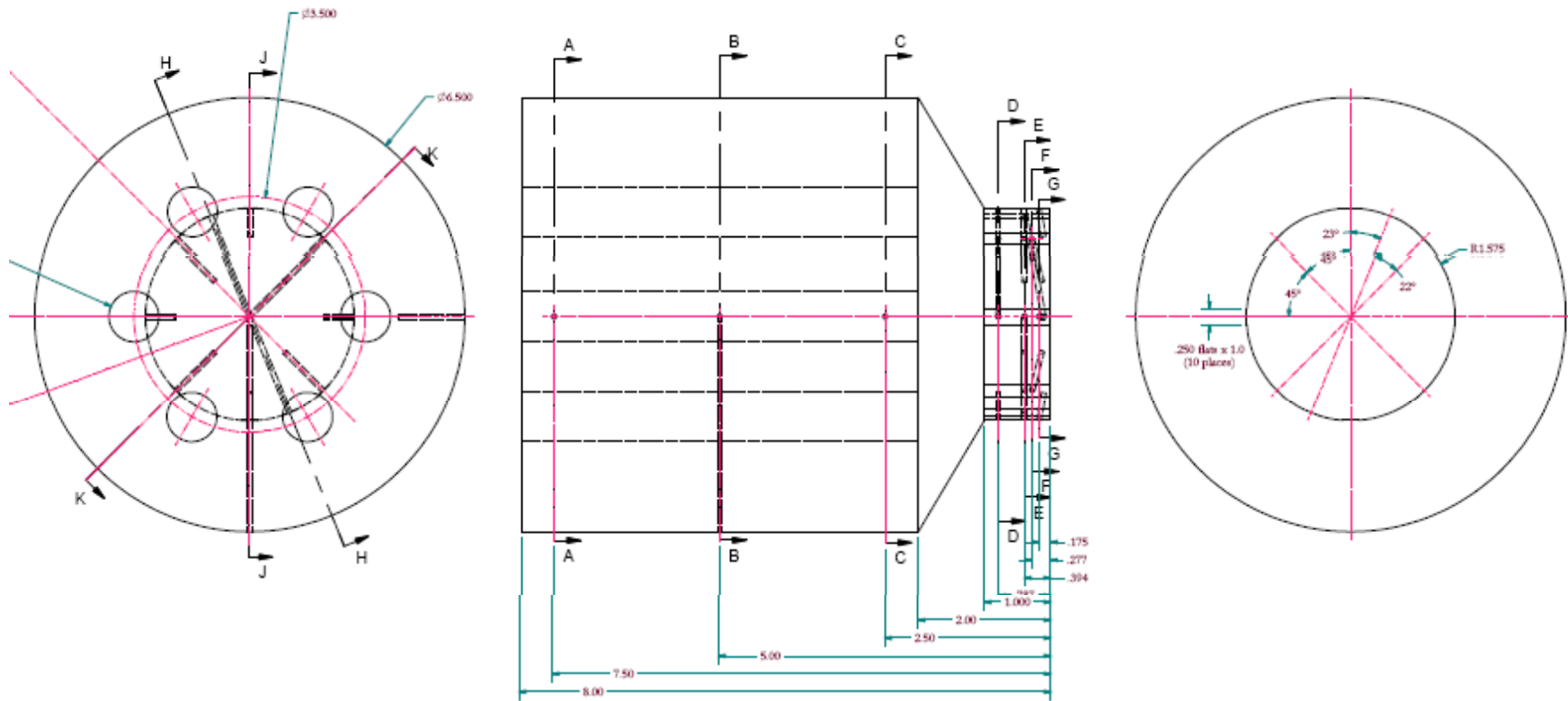

Estimated values AT LENS

Target Cooling

Heat Transfer

Flat plate heat exchange

6 gal/min = 20 liter/min

R = 4000

At Max power,

13 kW \longrightarrow 2.5 MW/m²

$T_{\text{wall}} - T_{\text{fluid}} = 288 \text{ K}$

Critical heat flux 2 ~ 4 MW/m²